

## Characterization of Carbon Dots Covered with Polyvinylpyrrolidone and Polyethylene Glycol

Jiri Kudr<sup>1,2</sup>, Lukas Richtera<sup>1,2</sup>, Lukas Nejd<sup>1,2</sup>, Iva Blazkova<sup>1,2</sup>, Vedran Milosavljevic<sup>1,2</sup>, Zdenek Moravec<sup>3</sup>, Dorota Wawrzak<sup>4</sup>, Pavel Kopel<sup>1,2</sup>, Branislav Ruttkay-Nedecky<sup>1,2</sup>, Vojtech Adam<sup>1,2</sup>, Rene Kizek<sup>1,2,\*</sup>

<sup>1</sup>Department of Chemistry and Biochemistry, Laboratory of Metallomics and Nanotechnology, Mendel University in Brno, Zemedelska 1, CZ-613 00 Brno, Czech Republic, European Union

<sup>2</sup>Central European Institute of Technology, Brno University of Technology, Technicka 3058/10, CZ-616 00 Brno, Czech Republic, European Union

<sup>3</sup>Department of Chemistry, Masaryk University, Kotlarska 2, CZ-611 37 Brno, Czech Republic, European Union

<sup>4</sup>Institute of Chemistry, Environmental Protection and Biotechnology, Jan Dlugosz University of Czestochowa PL-42-201, Poland, European Union

\*E-mail: [kizek@sci.muni.cz](mailto:kizek@sci.muni.cz)

Received: 15 June 2015 / Accepted: 11 July 2015 / Published: 26 August 2015

---

Luminescent carbon dots are new type of nanomaterial with possible applications in labelling and imaging due to their optoelectronic properties and their superior biocompatibility. The aim of this study was to synthesize two types of C-dots with different polymeric surface modification and to characterize them. Thermal method was used to prepare C-dots with surface stabilization with polyvinylpyrrolidone and polyethylene glycol. Several optical and electrochemical methods were used to characterize the particles. It was found that C-dots-PEG ( $3 \pm 2$  nm) possess stronger emission than C-dots-PVP ( $9 \pm 3$  nm) within the whole range of excitation wavelengths from 230 to 390 nm. Nevertheless in both cases the portion of C-dots created fluorescent micro-sized particles. Electrochemical impedance spectroscopy revealed that the electrode modified with both types of C-dots significantly increased resistance of bare glassy carbon electrode (C-dots-PVP 34-times and C-dots-PEG 141-times). In addition, it was found that pure polymers and C-dots also exhibit complex concentration dependent behaviour in Brdicka solution measured using hanging mercury drop electrode, whereas low amount added resulted in Co(II) peak (-1.3 V) shift and further resulted in three unresolved peak evolution between -0.5 and -0.9 V.

---

**Keywords:** Brdicka reaction, carbon dots, nanoparticles, voltammetry, glassy carbon electrode

## 1. INTRODUCTION

Fluorescent semiconductor nanometer-sized crystals called quantum dots (QDs) have been attracting attention of scientist due to their size-dependent optoelectronic properties. Their unique properties are being used in several applications including imaging, sensors and photovoltaics [1-3]. In comparison with fluorescent organic dyes they possess a lot of advantages as excellent photostability, broad excitation wavelengths, high quantum yield and resistance against photobleaching. On the other hand, an intrinsic toxicity of several QDs precursors limits their application under certain conditions, but in comparison to organic dyes their toxicity is lower [4]. Several mechanisms were suggested to be responsible for QDs toxicity as corrosion of the outer sphere caused by photooxidation leading to toxic ion release, formation of reactive oxygen species (ROS) or induction of genotoxic stress [5-7].

The search for nontoxic QDs-like nanomaterial resulted in finding that carbon nanoparticles passivated by organic or biological molecules (carbon dots, C-dots) exhibit strong fluorescence in the visible or infra-red spectrum due to passivated hydroxyl and/or carboxyl groups, superior water dispersibility and were found to be photochemically and physicochemically stable similar to QDs [8]. In comparison with non-carbon-based QDs, the building block of C-dots is not generally considered as toxic. Nevertheless there were concerns since other carbon nanomaterials like fullerenes and carbon nanotubes were found to have negative effects on living organisms [9-11]. *In vitro* toxicity of C-dots was tested in several studies and none or little adverse effects were reported [12,13]. Negative effects of polyethylene glycol (PEG) passivated C-dots were tested using MCF-7, HT-29 cells and mice and no significant toxicity of C-dots in comparison with PEG molecules were reported [14]. The molecule used for surface passivation seems to have bigger influence on C-dots toxicity than carbon nanomaterial alone [15]. Due to these, extensive efforts were devoted to precise C-dots synthesis. Chemical "bottom-up" (electrochemical, thermal or acidic oxidation, microwave synthesis) methods use molecular precursors like citric acid, glucose or phenolic resin as a carbon source, whereas physical "top-down" methods (laser ablation or plasma treatment) prepare C-dots from bigger materials (nanodiamonds, graphite, carbon nanotubes) [16-27]. Numerous organic molecules served as a C-dots surface passivator. Sun et al. used diamine-terminated PEG with average  $n \sim 35$  and poly(propionylethylene-imine-co-ethyleneimine) in order to stabilize C-dot surface [8].

As it was mentioned previously, C-dots are new type of nanomaterial. Nanoparticles are broadly used in electroanalysis due to many advantages they represent including increased catalytic activity, higher signal-to-noise ratio or improved selectivity. Electrochemical methods are alternative and cost-effective ways to characterize nanoparticles. They are mostly used in order to elucidate nanoparticles surface properties and reactivity in solution [28-30]. Although Compton's group focused on electrochemical determination of size, concentration and aggregation of metal and metal oxide nanoparticles, only few studies are reporting direct electrochemical characterization of C-dots and this research is at a very early stage [31-33]. In this study C-dots covered with polyvinylpyrrolidone (PVP) and PEG are successfully synthesized. Purified products of synthesis are further characterized with optical and electrochemical techniques.

## 2. EXPERIMENTAL PART

### 2.1. Chemicals and material

All chemicals were purchased from Sigma-Aldrich (St. Louis, MO, USA). Stock solutions were prepared in ACS water (Sigma-Aldrich, St. Louis, MO, USA) immediately prior to use.

### 2.2. C-dots synthesis

General method for the preparation of water soluble C-dots was adopted according to Wang et al. [34]. Briefly, in the case of C-dots covered with polyethylene glycol (C-dots-PEG), 10.0 ml of ethylene glycol, 1.0 g of polyethylene glycol solution (average  $M_w \sim 8$  kDa) and 1.0 g of citric acid were added into a 100 ml three-neck flask. The solution was heated at 180 °C for four hours under protective flow of nitrogen, and then cooled down to room temperature. Into the cooled solution, water was added and then stirred for a few minutes. The solution was purified 24 h by dialyzing against water with a D-Tube maxi dialyzer with 3.5 kDa cut-off (Merck, Darmstadt, Germany). During 24 hours of dialysis ethylene glycol was removed from solution. C-dots covered with polyvinylpyrrolidone (C-dots-PVP) were synthesized similarly except that polyvinylpyrrolidone solution (average  $M_w \sim 10$  kDa) was used instead of PEG and the solution was heated on 120 °C for 24 hours. Both samples were then centrifuged at 10 000 RPM and the supernatants were used in the following experiments.

### 2.3. Optical properties measurements

Absorption spectra of C-dots were recorded within the range from 230 to 800 nm by a spectrophotometer SPECORD 210 (Analytik Jena, Jena, Germany) using plastic UV-transparent cuvettes with 1 cm optical path (Brand, Wertheim, Germany) at 25 °C maintained by Julabo (Labortechnik, Wasserburg, Germany). The changes in absorbance spectra of the samples were recorded and evaluated using the program WinASPECT version 2.2.7.0. Fluorescence spectra were acquired by multifunctional microplate reader Tecan Infinite 200 PRO (TECAN, Männedorf, Switzerland) in Corning UV-transparent 96 well plates (Corning, New York, USA). The volumes of measured samples were 100  $\mu$ l and each intensity value was an average of 5 measurements. The detector gain was set to 100. Average particle size and size distribution were determined by dynamic light scattering method by Zetasizer Nano-ZS (Malvern Instruments Ltd., Worcestershire, United Kingdom) with a scattering angle  $\theta = 173^\circ$ . The IR spectra (4000–400  $\text{cm}^{-1}$ ) were recorded on a Bruker Tensor 27 spectrometer (Bruker, Karlsruhe, Germany) equipped with platinum-ATR accessory with diamond crystal.

Microscopic studies were performed using an inverted Olympus IX 71S8F-3 fluorescence microscope (Olympus, Tokyo, Japan) equipped with Olympus UIS2 series objective LUCPlanFLN 40 $\times$  (N.A. 0.6, WD 2.7 – 4 mm, F.N. 22) and a mercury arc lamp X-cite 120 Lamp (120 W, Lumen Dynamics, Mississauga, Canada) for illumination. The fluorescence mirror units used in our study had

excitation wavelength: 360 – 370 nm, emission wavelength: 420 – 460 nm, dichroic mirror: 400 nm (blue fluorescence); excitation wavelength: 460 – 495 nm, emission wavelength: 510 – 550 nm, dichroic mirror: 505 nm (green fluorescence); excitation wavelength: 510 – 550 nm, emission wavelength: 590 nm, and dichroic mirror: 570 nm (red fluorescence). Images were acquired with a Camera Olympus DP73 (Olympus, Tokyo, Japan) and processed by Stream Basic 1.7 software (Olympus Soft Imaging Solutions GmbH, Münster, Germany) with the software resolution of 1,600 × 1,200 pixels.

#### 2.4. Electrochemical impedance measurements

Electrochemical experiments were carried out using a standard three-electrode system at 25 °C. The reference electrode was an Ag/AgCl/3M KCl electrode and the counter electrode a platinum wire (both CH Instruments, Austin, USA). Glassy carbon electrode with 3 mm in diameter (CH Instruments, Austin, USA) was used to determine formal potential of  $[\text{Fe}(\text{CN}_6)]^{3-}$  reduction. In order to it, cyclic voltammograms (scan rate  $50 \text{ mV}\cdot\text{s}^{-1}$  in potential range  $-0.3 - 0.7 \text{ V}$ ) were measured in the presence of 2 mM  $\text{K}_3[\text{Fe}(\text{CN}_6)]^{3-}/\text{K}_4[\text{Fe}(\text{CN}_6)]^{4-}$  (1:1) solution in 0.1 M KCl (pH 7). The formal potential was subsequently used as the potential of electrochemical impedance spectroscopy (EIS) measurement (AC amplitude 10 mV, range  $0.1 - 10^5 \text{ Hz}$ ). The same procedure was performed with C-dots modified GCE (5  $\mu\text{l}$  of C-dots were spread on the surface of GCE and let to evaporate). The signals were recorded using potentiostat PGSTAT302N (Metrohm, Herisau, Switzerland) with frequency response analyser and evaluated using software NOVA 1.8 (Metrohm, Herisau, Switzerland). Equivalent circuits and calculation of equivalent circuit parameters was performed on the same software. The glassy carbon electrode (GCE) was mechanically polished by the 0.1  $\mu\text{m}$  alumina suspension (ESA Inc., Chelmsford, USA) on polishing cloth to produce mirror-like surface. Then, the electrode was sonicated for 1 min in acetone and deionised water (25 °C) in the Sonorex digital 10 P ultrasonic bath (Bandelin, Berlin, Germany), respectively.

#### 2.5. Differential pulse voltammetric measurements

Determination of pure PVP, pure PEG, CQDs modified by PVP, and CQDs modified by PEG was performed by differential pulse voltammetry (DPV) using 663 VA Computrace instrument (Metrohm, Herisau, Switzerland), equipped with a standard cell with three electrodes. A hanging mercury drop electrode (HMDE) with a drop area of  $0.4 \text{ mm}^2$  (Metrohm, Herisau, Switzerland) was employed as the working electrode. An Ag/AgCl/3M KCl (CH Instruments, Austin, USA) electrode was used as the reference electrode and carbon electrode served as auxiliary. For data processing 663 VA Computrace software by Metrohm (Metrohm, Herisau, Switzerland) was employed. The samples were deoxygenated prior to measurements by purging with argon (99.999%). The Brdicka supporting electrolyte containing 1 mM  $[\text{Co}(\text{NH}_3)_6]\text{Cl}_3$  and 1 M ammonia buffer ( $\text{NH}_3(\text{aq}) + \text{NH}_4\text{Cl}$ , pH = 9.6) was used. The supporting electrolyte was exchanged after each analysis. The analyte was mixed with Brdicka solution to obtain 2 ml. The parameters of the measurement by DPV as follows: initial

potential of -0.55 V, end potential -1.80 V, deoxygenating with argon 30 s, deposition 0 s, time interval 0.8 s, step potential 4.95 mV, modulation amplitude 25.05 mV, modulation time 0.03 s and scan rate  $6.19 \text{ mV}\cdot\text{s}^{-1}$ . For electrochemical measurement the total volume 2 ml was used. Peak heights were measured from linear baseline (tangent to the curve joining beginning and end of the given peak). All measurements were carried out on air at temperature  $6 \pm 0.1 \text{ }^\circ\text{C}$  controlled with a JULABO F12/ED thermostat (Labortechnik GmbH, Germany).

### 3. RESULTS AND DISCUSSION

#### 3.1. Spectral properties

We adopted procedure to synthesize water soluble C-dots from Wang et al. and did slight modifications using ethylene glycol as solvent instead of glycerol [34]. Performed experiments were carried out parallel with two water soluble C-dots covered by different polymeric materials – PEG and PVP. Due to the fact that quantum dots and C-dots possess unique optoelectronic properties, at first spectrophotometric and fluorescence characterization was performed. The absorption spectra showed local absorption maxima app. 300 nm in the case of C-dots-PEG (Fig. 1Ab), but very weak absorption in this region in the case of C-dots-PVP (Fig. 1Aa). The absorption peak app. 300 nm was previously observed in the case of C-dots [24,35]. Different excitation wavelengths were used for excitation of C-dots complex with polymeric surface agents and the emission was found to be the strongest after excitation at 250 nm (Fig. 1B). Sharp decreases of fluorescence were observed in the case of excitation wavelength 310 nm. We suggest that the emissions after excitation at wavelengths higher than 310 nm are caused especially by aggregated polymers C-dots complex, but after filtration and centrifugation of samples obtained by synthesis, emission at these wavelengths significantly decreased (not shown). In further experiments the separated samples were used. Fluorescent microscope was used to visualize the micro-sized particles presented within sample and the particles of size app.  $25 \mu\text{m}$  were observed (Figs. 1C and D). In order to elucidate the presence of fluorescent C-dots within samples, the fluorescence spectra of 1 % *w/v* capping polymers was compared with C-dots samples. PVP is weakly fluorescent polymer and as it can be seen in Fig. 1E and reaches fluorescence emission maxima at 305 nm. Nevertheless C-dots-PVP maxima are shifted to 360 nm (Fig. 1Ea). Dynamic light scattering measurements revealed the C-dots-PVP particles size  $9 \pm 3 \text{ nm}$  (33 % of particles of 9 nm), as it is shown in Fig. 1F. Wang et al. mentioned that heated PEG in glycerol produces no fluorescent species [34]. We observed weak fluorescence of 1 % *w/v* PEG dissolved in water at 336 nm, but compared with emission maxima of C-dots-PEG at 384 nm it represents only 3.3 % (Fig. 1G). The size distribution of C-dots-PEG particles was determined from 2 to 6 nm with 27 % of particles of 3 nm size (Fig. 1H).

Furthermore, infrared spectra of C-dots were measured and compared with 1 % (*w/v*) solution of polymers. In the case of C-dots-PVP (Fig. 1 I) several vibrations, which differ from polymer solution, were observed. Namely strong signals appeared at wavenumber  $1340 \text{ cm}^{-1}$  and  $1398 \text{ cm}^{-1}$ . Few differences were also found in the region between  $1348$  and  $1490 \text{ cm}^{-1}$ , where the original three

signals of pure PVP doubled in the case of C-dots modified with PVP. This can be the consequence of C-dots and PVP functional groups interaction. Two differences were observed when spectra of C-dots-PEG and PEG solution were compared (fig. 1 J). If we take into account peak intensities at  $1352\text{ cm}^{-1}$ , which are more or less the same, C-dots provided strong signal also at  $1339\text{ cm}^{-1}$ . In addition, new signal at  $1420\text{ cm}^{-1}$  appeared. Several infrared spectra differences between C-dots and polymers suggest that strong interactions between C-dots and their polymeric cover take place. Comparison between both C-dots spectra also indicate that these differences are not caused by C-dots itself, although peaks at  $1348\text{ cm}^{-1}$  were observed in case of both C-dots.

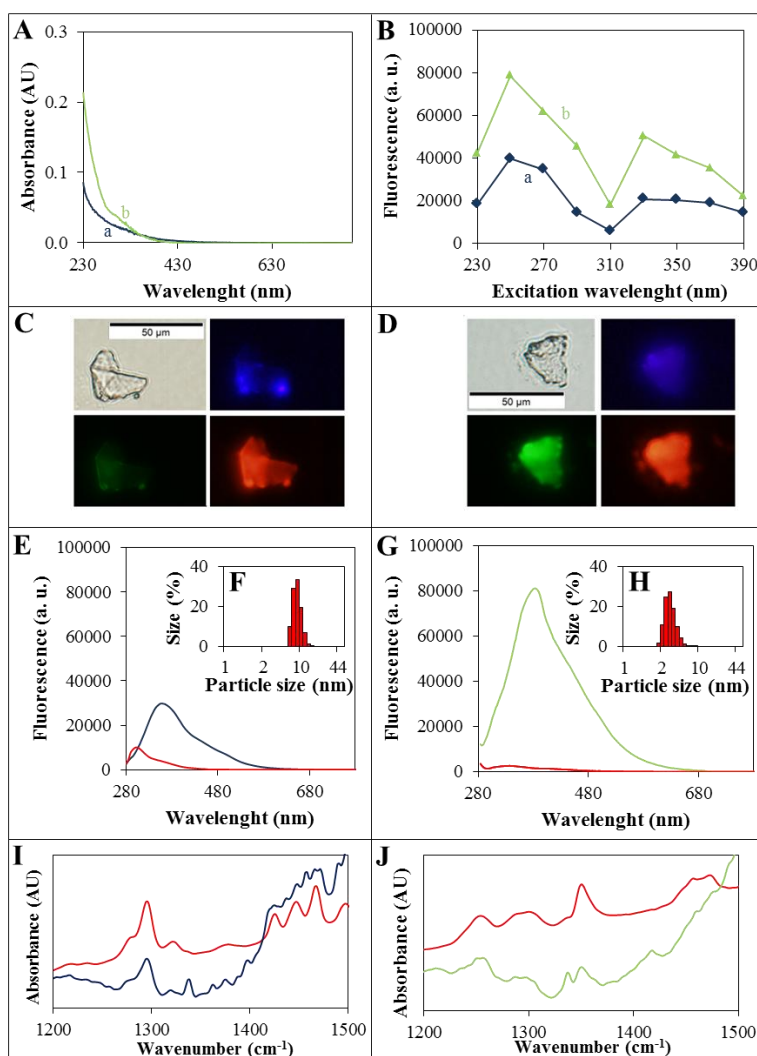

**Figure 1.** (A) Absorption spectra (230 – 800 nm) and (B) dependence of emission maxima on excitation wavelength of (a) C-dot-PVP and (b) C-dots-PEG. The photos of fluorescent micro-sized particles obtained by fluorescence microscope in (C) C-dots-PVP and (D) C-dots-PEG sample. Comparison of C-dot-PVP (blue line) and C-dots-PEG (green line) (E, G) emission ( $\lambda_{exc}$  250 nm) with 1 % w/v polymers (red line), which passivate them. Size distribution of nanoparticles presented within (F) C-dots-PVP and (H) C-dots-PEG sample. Infrared spectra of 1 % w/v PVP (red line) with C-dots-PVP (blue line) (I) and 1 % w/v PEG (red line) with C-dots-PEG (green line) (J).

### 3.2. Electrochemical properties

Electrochemical properties of C-dots-PVP and C-dots-PEG were studied using ferrocyanide/ferricyanide redox probe. For comparative purpose, cyclic voltammograms and electrochemical impedance spectra of bare glassy carbon electrode (GCE) were measured. As McCreery mentioned  $[\text{Fe}(\text{CN})_6]^{3-/4-}$  is often used as the simplest example of outer sphere electron transfer reaction [36]. In fact,  $[\text{Fe}(\text{CN})_6]^{3-/4-}$  redox properties depends strongly on the surface properties of carbon or more precisely on presence of functional groups, which can be occupied by adsorbates [37]. C-dots were physically adsorbed on the surface of GCE and cyclic voltammograms of  $[\text{Fe}(\text{CN})_6]^{3-/4-}$  were measured (Fig. 2A). It is well-known that peak-to-peak separation ( $\Delta E$ ) increases as electron transfer to electrode decreases. In comparison with bare polished GCE (83 mV),  $\Delta E$  of GCE modified with both C-dots significantly increased, thus electron transfer is slower. In the case of C-dots-PVP it increased by 110 % to 175 mV and in the case of C-dots-PEG by nearly 4-times to 410 mV. These results were confirmed also by electrochemical impedance spectroscopy (EIS). We measured impedances of system at formal potential of  $[\text{Fe}(\text{CN})_6]^{3-/4-}$  redox couple in 0.1 M KCl obtained by CV measurement. Modified Randles circuit was used to fit the data of GCE impedance. In order to quantify impedance parameters of GCE modified with C-dots equivalent circuit shown in Fig. 2B was used and it consisted of the following parts: electrolyte resistance  $R_e$ , with in series resistance of C-dots  $R_1$  and constant phase element CPE ( $Z_{\text{CPE}} = 1/j(\omega Q)^n$ ) representing C-dots layer, charge transfer resistance  $R_{ct}$ , double layer capacitance  $C_{dl}$  and Warburg element  $Z_w$  (impedance of the Faradaic reaction). The CPE was used instead of simple capacitor since we presume inhomogeneity of C-dots layer on GCE. It can be seen that the fitted data follow the same pattern as the measured data, although especially in the case of C-dots-PEG it was necessary to use CPE. From the fitting, we know that constant phase elements  $n$  was in both GCE modified with C-dots-PVP and C-dots-PEG higher than 0.9 and both layers can be considered as a capacitive approximately. The Nyquist plot often consists of two different parts – the semi-circle in higher frequencies, which diameter corresponds to charge transfer resistance, and linear with slope around 0.5 which represents diffusion controlled process. Since the resistances ( $R_1$  and  $R_{ct}$ ) were in series, the resistance of system  $R_s$  (without electrolyte resistance) follows the expression:

$$R_s = R_1 + R_{ct}$$

As it can be seen in Fig. 2C, C-dots layer on the surface of GCE decreases electron transfer- to GCE. The fitting procedure yielded the resistance value of GCE modified with C-dots-PVP  $141 \text{ k}\Omega \cdot \text{cm}^{-2}$  and of C-dots-PEG  $583 \text{ k}\Omega \cdot \text{cm}^{-2}$ , which are consistent with CV measurements. These measurements suggest that polymers fully cover the C-dots surface and electrons are not able to pass through carbon core of dots.

The aim was to compare electrochemical properties of C-dots with 1% (w/v) water solutions of polymers, which stabilize their surface. In order to do so, Brdicka solution was used. Brdicka reaction is broadly used analytical method to determine sulphur rich proteins/peptides (e.g. metallothioneins) [38-47]. This reaction is based on reduction of hydrogen on the mercury electrode catalysed by –SH moiety in cysteine or methionine in ammonia buffer containing cobalt ions [48]. Proteins/peptides

provide in Brdicka solution four distinct signals, however in the case of pure Brdicka solution Co(II) peak app. potential -1.15 V can be observed only [39,49,50].

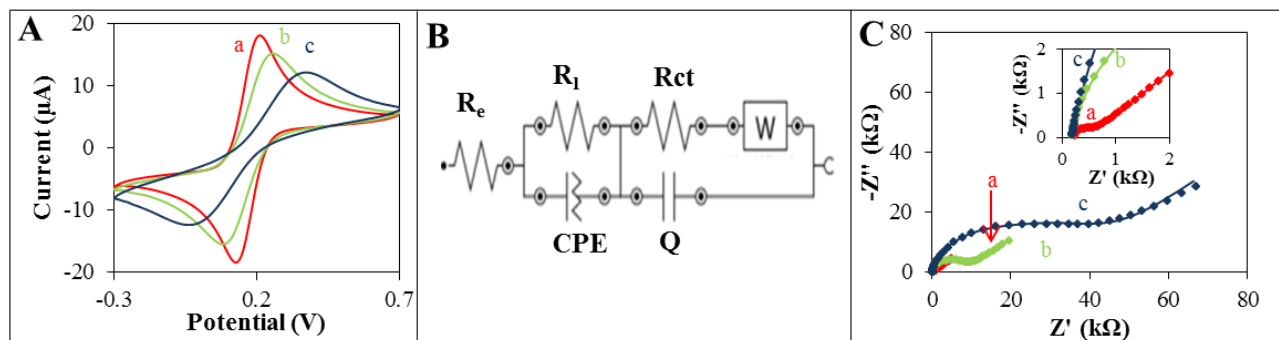

**Figure 2.** (A) Cyclic voltammogram of equimolar 4 mM  $K_3[Fe(CN)_6]^{3-}/K_4[Fe(CN)_6]^{4-}$  solution in 0.1 M KCl obtained by (a) GCE, (b) GCE modified with C-dots-PVP and (c) C-dots-PEG. (B) The equivalent circuit used for modified GCE parameters quantification and (C) Nyquist plot obtained by (a) GCE, (b) GCE modified with C-dots-PVP and (c) C-dots-PEG in mentioned solution (solid lines represents the fitting curve).

Measurement of Brdicka solution provided in our experimental setting peak of cobalt ions at potential -1.28 V due to quite different measurement conditions compared with cited articles. The further shift of this peak was also observed after addition of polymers alone (1% (w/v)) and C-dots covered with both polymers. In the case of PVP the Co(II) peak shifted slightly to -1.29 V and peak current increased by 16 %, nevertheless higher additions of PVP lead to further shifting and finally resulted in the peak stabilization at -1.38 V together with the decrease of the peak height (current). The complex evolution of signals between potentials -0.5 and -1.0 V was observed after the Co(II) peak stabilization after addition of more than 2.5  $\mu$ l of PVP, whereas the wide peak at potential -0.81 V started to appear and with higher additions shifted to higher potentials and addition of more than 4.5  $\mu$ l resulted in appearance and shift of narrow peak at higher potentials (Fig. 3A). To describe this behaviour the currents at fixed potentials -0.57 (blue column), -0.65 (green column) and -0.79 V (red column) were plotted against added amount of polymer (Fig. 3B). As it can be seen, the growing values of current at -0.79 V are describing more or less evolution of wide peak and blue and green narrow on its background. In comparison with alone PVP approximately ten time higher amounts of C-dots is needed to be added to observe the same changes in voltammograms. Nevertheless the different electrochemical behaviour of C-dots-PVP were observed in comparison with alone PVP (Fig. 3C). Although peak was gently developing with addition of C-dots narrow peak b was well developed and shifted significantly mildly in case of polymer (blue line in Fig. 3D).



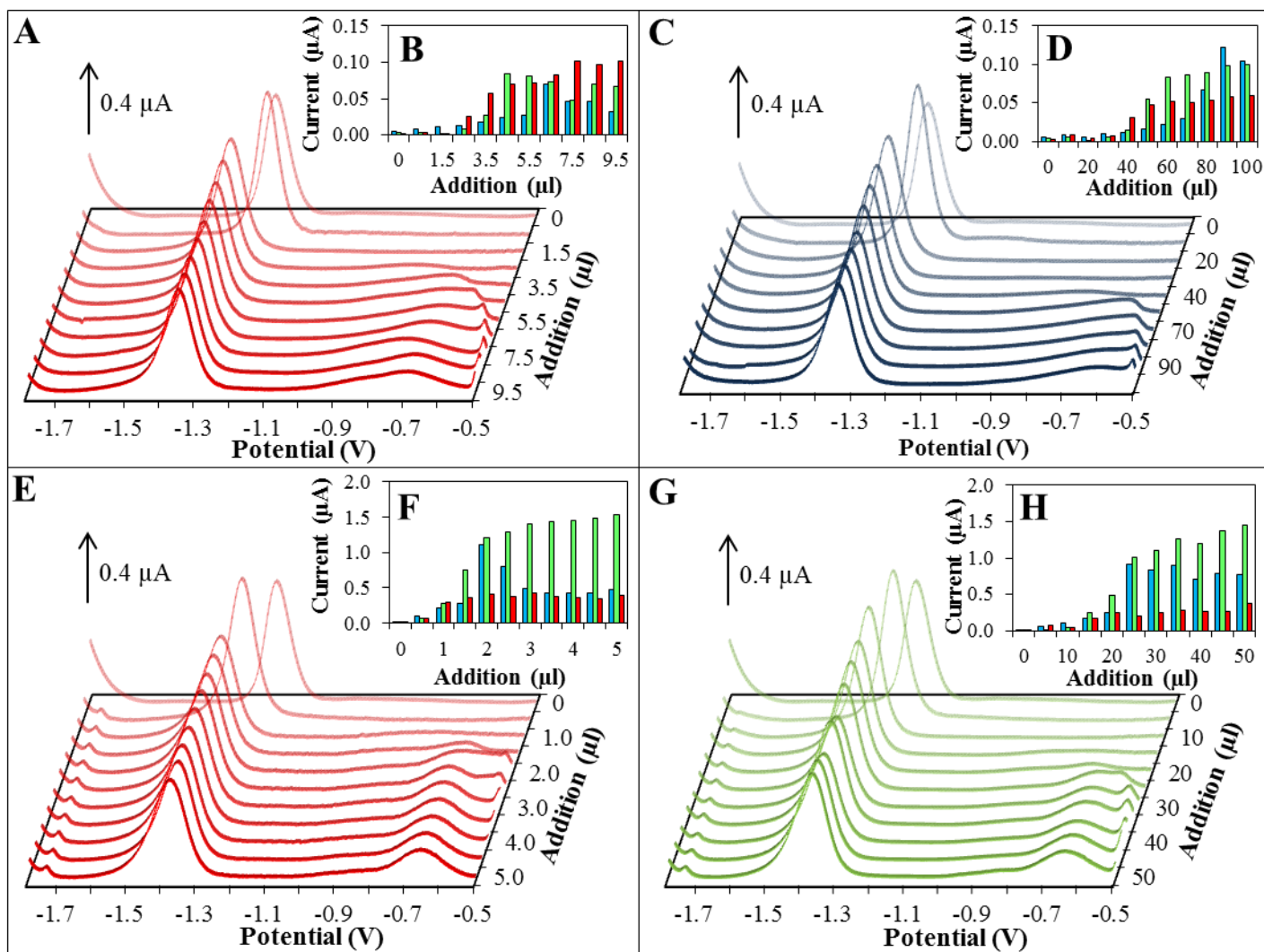

**Figure 3.** The voltammograms and the dependence of current levels at potentials -0.57 V (blue), -0.65 V (green) and -0.79 V (red) of (A, B) 1% PVP, (C, D) C-dots-PVP, (E, F) 1% PEG and (G, H) C-dots-PEG added to electrochemical cell in precise volume.

The electrochemical determination of PEG using Brdicka reaction revealed similar behaviour as PVP. The initial addition of polymer (0.5 and 1.0 μl) to electrochemical cell caused no evolution of additional peak and resulted only in Co(II) peak shift to lower potentials. The increase in peak current was observed after first addition of 0.5 μl. Next addition of PVP lead to decrease of Co(II) peak by 20 % and the next polymer addition did not influence peak current and position any more. It can be suggested that the similarly as in the previous case, PEG is able to form complex with Co(II). In the case of pure PEG, the peak at -0.69 V was observed after addition of 1.5 μl of 1 % PEG (w/v), as it is shown in Fig. 3E. Subsequent polymer additions resulted in the increase of this peak and gentle shift to potential -0.71 V. The behaviour of these parts of voltammograms is depicted in Fig. 3F blue, green and red columns represent potentials -0.61, -0.70 and -0.90 V, respectively. The addition of C-dots-PEG and also PEG into electrochemical cell resulted in the occurrence of small peak at -1.75 V. The differences between PEG and C-dots modified with PEG were minor in comparison with case of PVP (Fig. 3G). Nevertheless, some differences at the potential of -0.65 V can be observed and are displayed

in Fig. 3H. As it was mentioned previously, Brdicka reaction is method for quantification of –SH moieties. In this case, peaks in lower potentials than -1.0 V are evaluated. In our samples no sulphur was presented, however the evolution of signals between -1.0 and -0.5 V was observed. Although it was not possible to measure calibration curves from data obtained for both C-dots and pure polymers, which would enable us to determine polymers concentrations precisely, it is evident that specific shape of curve (peak positions and heights) corresponds with specific polymer concentration. It seems that mathematical evaluation of obtained voltammograms can be used for determination of PVP and PEG concentrations and indirectly for concentration of C-dots.

#### 4. CONCLUSIONS

In this paper basic optical and electrochemical characterizations of two types of C-dots modified with polyvinylpyrrolidone and/or polyethylene glycol were performed. It was shown that these nanoparticles possess fluorescent properties within broad range of excitation wavelengths and mentioned polymers stabilize their surface. The electrochemical measurements suggested that C-dots covered with polymers are not suitable to modify electrode surface in order to improve detection parameters. Nevertheless C-dots and polymers were determined using Brdicka reaction. These results suggest that this method can provide, after further research, alternative to C-dots concentration determination. Quantification of C-dots concentrations using Brdicka reaction would be innovative and reasonable alternative for indirect determination of C-dots concentration. However, relatively complicated shapes of voltammograms don't enable standard evaluation and require application of advanced mathematical model, which will be object of further researches.

#### ACKNOWLEDGEMENTS

The financial support from IGA MENDELU IP-05-2015 is highly acknowledged.

#### Conflict of interest

The authors have declared no conflict of interest.

#### References

1. J. Lee, J. S. Choi and M. Yoon, *J. Mat. Chem. B*, 2 (2014) 2311.
2. Z. Heger, N. Cernei, S. Krizkova, M. Masarik, P. Kopel, P. Hodek, O. Zitka, V. Adam and R. Kizek, *Sci. Rep.*, 5 (2015) 1.
3. N. E. Hjerrild, D. C. J. Neo, A. Kasdi, H. E. Assender, J. H. Warner and A. A. R. Watt, *ACS Appl. Mater. Interfaces*, 7 (2015) 6417.
4. M. Ryvolova, J. Chomoucka, J. Drbohlavova, P. Kopel, P. Babula, D. Hynek, V. Adam, T. Eckschlager, J. Hubalek, M. Stiborova, J. Kaiser and R. Kizek, *Sensors*, 12 (2012) 14792.
5. J. Aldana, Y. A. Wang and X. G. Peng, *J. Am. Chem. Soc.*, 123 (2001) 8844.
6. A. C. S. Samia, X. B. Chen and C. Burda, *J. Am. Chem. Soc.*, 125 (2003) 15736.
7. A. O. Choi, S. E. Brown, M. Szyf and D. Maysinger, *J. Mol. Med.*, 86 (2008) 291.

8. Y. P. Sun, B. Zhou, Y. Lin, W. Wang, K. A. S. Fernando, P. Pathak, M. J. Mezziani, B. A. Harruff, X. Wang, H. F. Wang, P. J. G. Luo, H. Yang, M. E. Kose, B. L. Chen, L. M. Veca and S. Y. Xie, *J. Am. Chem. Soc.*, 128 (2006) 7756.
9. A. A. Shvedova, V. Castranova, E. R. Kisin, D. Schwegler-Berry, A. R. Murray, V. Z. Gandelsman, A. Maynard and P. Baron, *J. Toxicol. Env. Health Pt. A*, 66 (2003) 1909.
10. S. Hirano, S. Kanno and A. Furuyama, *Toxicol. Appl. Pharmacol.*, 232 (2008) 244.
11. C. M. Sayes, J. D. Fortner, W. Guo, D. Lyon, A. M. Boyd, K. D. Ausman, Y. J. Tao, B. Sitharaman, L. J. Wilson, J. B. Hughes, J. L. West and V. L. Colvin, *Nano Lett.*, 4 (2004) 1881.
12. W. H. Shang, X. Y. Zhang, M. Zhang, Z. T. Fan, Y. T. Sun, M. Han and L. Z. Fan, *Nanoscale*, 6 (2014) 5799.
13. N. Zhou, S. J. Zhu, S. Maharjan, Z. Y. Hao, Y. B. Song, X. H. Zhao, Y. F. Jiang, B. Yang and L. J. Lu, *RSC Adv.*, 4 (2014) 62086.
14. S. T. Yang, X. Wang, H. F. Wang, F. S. Lu, P. J. G. Luo, L. Cao, M. J. Mezziani, J. H. Liu, Y. F. Liu, M. Chen, Y. P. Huang and Y. P. Sun, *J. Phys. Chem. C*, 113 (2009) 18110.
15. Y. L. Wang, P. Anilkumar, L. Cao, J. H. Liu, P. J. G. Luo, K. N. Tackett, S. Sahu, P. Wang, X. Wang and Y. P. Sun, *Exp. Biol. Med.*, 236 (2011) 1231.
16. Q. L. Zhao, Z. L. Zhang, B. H. Huang, J. Peng, M. Zhang and D. W. Pang, *Chem. Commun.*, 44 (2008) 5116.
17. D. Y. Pan, J. C. Zhang, Z. Li, C. Wu, X. M. Yan and M. H. Wu, *Chem. Commun.*, 46 (2010) 3681.
18. H. P. Liu, T. Ye and C. D. Mao, *Angew. Chem.-Int. Edit.*, 46 (2007) 6473.
19. Q. L. Wang, H. Z. Zheng, Y. J. Long, L. Y. Zhang, M. Gao and W. J. Bai, *Carbon*, 49 (2011) 3134.
20. S. K. Yang, H. B. Zeng, H. P. Zhao, H. W. Zhang and W. P. Cai, *J. Mater. Chem.*, 21 (2011) 4432.
21. H. Q. Jiang, F. Chen, M. G. Lagally and F. S. Denes, *Langmuir*, 26 (2010) 1991.
22. S. J. Yu, M. W. Kang, H. C. Chang, K. M. Chen and Y. C. Yu, *J. Am. Chem. Soc.*, 127 (2005) 17604.
23. L. Y. Zheng, Y. W. Chi, Y. Q. Dong, J. P. Lin and B. B. Wang, *J. Am. Chem. Soc.*, 131 (2009) 4564.
24. J. G. Zhou, C. Booker, R. Y. Li, X. T. Zhou, T. K. Sham, X. L. Sun and Z. F. Ding, *J. Am. Chem. Soc.*, 129 (2007) 744.
25. H. Peng and J. Travas-Sejdic, *Chem. Mat.*, 21 (2009) 5563.
26. V. Milosavljevic, H. V. Nguyen, P. Michalek, A. Moulick, P. Kopel, R. Kizek and V. Adam, *Chem. Pap.*, 69 (2015) 192.
27. R. L. Liu, D. Q. Wu, S. H. Liu, K. Koynov, W. Knoll and Q. Li, *Angew. Chem.-Int. Edit.*, 48 (2009) 4598.
28. L. Colmenares, Z. Jusys and R. J. Behm, *Langmuir*, 22 (2006) 10437.
29. D. Hynek, K. Tmejova, V. Milosavljevic, A. Moulick, P. Kopel, V. Adam and R. Kizek, *Int. J. Electrochem. Sci.*, 10 (2015) 1117.
30. D. Battistel, F. Baldi, M. Gallo, C. Faleri and S. Daniele, *Talanta*, 132 (2015) 294.
31. Y. G. Zhou, N. V. Rees and R. G. Compton, *Angew. Chem.-Int. Edit.*, 50 (2011) 4219.
32. N. V. Rees, Y. G. Zhou and R. G. Compton, *RSC Adv.*, 2 (2012) 379.
33. E. J. E. Stuart, N. V. Rees, J. T. Cullen and R. G. Compton, *Nanoscale*, 5 (2013) 174.
34. F. Wang, S. P. Pang, L. Wang, Q. Li, M. Kreiter and C. Y. Liu, *Chem. Mat.*, 22 (2010) 4528.
35. L. Cao, X. Wang, M. J. Mezziani, F. S. Lu, H. F. Wang, P. J. G. Luo, Y. Lin, B. A. Harruff, L. M. Veca, D. Murray, S. Y. Xie and Y. P. Sun, *J. Am. Chem. Soc.*, 129 (2007) 11318.
36. R. L. McCreery, *Chem. Rev.*, 108 (2008) 2646.
37. P. H. Chen and R. L. McCreery, *Anal. Chem.*, 68 (1996) 3958.

38. V. Adam, D. Chudobova, K. Tmejova, K. Cihalova, S. Krizkova, R. Guran, M. Kominkova, M. Zurek, M. Kremplova, A. M. J. Jimenez, M. Konecna, D. Hynek, V. Pekarik and R. Kizek, *Electrochim. Acta*, 140 (2014) 11.
39. H. V. Nguyen, Z. Heger, M. Kominkova, P. Michalek, J. Gumulec, R. Guran, A. Pridal, C. Fernandez, D. Hynek, V. Adam and R. Kizek, *Int. J. Electrochem. Sci.*, 10 (2015) 1249.
40. R. Kensova, D. Hynek, J. Kynicky, M. Konecna, T. Eckschlager, V. Adam, J. Hubalek and R. Kizek, *Int. J. Electrochem. Sci.*, 9 (2014) 4675.
41. V. Adam, I. Fabrik, T. Eckschlager, M. Stiborova, L. Trnkova and R. Kizek, *TRAC-Trends Anal. Chem.*, 29 (2010) 409.
42. L. Trnkova, S. Krizkova, V. Adam, J. Hubalek and R. Kizek, *Biosens. Bioelectron.*, 26 (2011) 2201.
43. R. Kizek, L. Trnkova and E. Palecek, *Anal. Chem.*, 73 (2001) 4801.
44. V. Adam, J. Petrlova, J. Wang, T. Eckschlager, L. Trnkova and R. Kizek, *PLoS ONE*, 5 (2010) e11441.
45. K. Tmejova, D. Hynek, P. Kopel, S. Krizkova, I. Blazkova, L. Trnkova, V. Adam and R. Kizek, *Colloid Surf. B-Biointerfaces* 117 (2014) 534.
46. P. Sobrova, L. Vyslouzilova, O. Stepankova, M. Ryvolova, J. Anyz, L. Trnkova, V. Adam, J. Hubalek and R. Kizek, *PLoS ONE*, 7 (2012) 1.
47. V. Adam, D. Chudobova, K. Tmejova, K. Cihalova, S. Krizkova, R. Guran, M. Kominkova, M. Zurek, M. Kremplova, A. M. Jimenez Jimenez, M. Konecna, D. Hynek, J. Pekarik and R. Kizek, *Electrochim. Acta*, 140 (2014) 11.
48. B. Raspor, *J. Electroanal. Chem.*, 503 (2001) 159.
49. H. V. Nguyen, K. Tmejova, L. Krejcova, D. Hynek, P. Kopel, J. Kynicky, V. Adam and R. Kizek, *Int. J. Electrochem. Sci.*, 9 (2014) 3364.
50. I. Fabrik, S. Krizkova, D. Huska, V. Adam, J. Hubalek, L. Trnkova, T. Eckschlager, J. Kukacka, R. Prusa and R. Kizek, *Electroanalysis*, 20 (2008) 1521.